



2023 OFFICIAL RULES

Version 1 - Effective As of March 1, 2023

Preface

This edition of the PFL Europe Official Rules (“Rules”) contains current rules, regulations, and procedures that are in effect for the PFL Europe’s 2023 season. The PFL may amend these rules at any time.

These Rules are posted at the following link: www.pfleurope.com/rules-regulations

PFL Europe, LLP
contact@pfleurope.com
www.pfleurope.com

Table of Contents

<i>Article</i>	<i>Page</i>
1. General	
1.1 - 2023 PFL Europe Season Format Overview	5
1.2 - Weight Divisions	5
1.3 - Commissions	5
1.4 - Code of Conduct	6
1.5 - No Elbows	6
1.6 - Gloves	6
1.7 - Apparel	7
1.8 - Technology	7
1.9 - Competition Space	8
1.10 - Appeal Process	8
2. Regular Season	
2.1 - Number of Fights	9
2.2 - Bout Specifications	9
2.3 - Results	9
2.4 - Determining of Opponents	10
2.5 - Making Weight	10
2.6 - Injuries and Replacements	10
2.7 - Failed Drug Tests	11
3. Semifinals	
3.1 - Seeding and Matchups	12
3.2 - Bout Specifications	12
3.3 - Tiebreakers	12
3.4 - Making Weight	13
3.5 - Alternates	13
3.6 - Injuries and Replacements	13
3.7 - Failed Drug Tests	13

4. Final	
4.1 - Bout Specifications	14
4.2 - Making Weight	14
4.3 – Matchups and Alternates	14
4.4 - Draws, No Contests and Walkovers	14
4.5 - Failed Drug Tests	15

1. General

1.1 – 2023 PFL Europe Season Format Overview

- a) The 2023 PFL Europe Season will consist of 4 events: 2 regular season events, 1 semifinal event, and 1 PFL Europe Final. The PFL can change the schedule at its discretion.
- b) There will be 4 PFL Europe weight divisions. Fighters will be scheduled to compete in 1 regular season fight, consisting of three 5-minute rounds.
- c) There will be 8 fighters in each weight division. The league reserves the right to add alternates and adjust the total number of fighters as needed.
- d) Fighters who win their regular season bout will progress into the semifinals.
- e) Semifinal winners will qualify for the PFL Europe Final.

1.2 - Weight Divisions

- a) The 2023 PFL Europe Season will feature 4 weight divisions: 3 men's divisions & 1 women's division.

Men's Divisions

Bantamweight - 135 lbs. / 61.2 kg

Lightweight - 155 lbs. / 70.3 kg

Light Heavyweight - 205 lbs. / 93.0 kg

Women's Division

Flyweight - 125 lbs. / 56.7 kg

- b) Fighters will be allowed a one-pound overage for regular season and semifinal bouts, subject to commission approval. Final bout competitors will not be given any weight allowance and will have to meet the upper limit of the division they are scheduled to compete in.
- c) Fighters in a division will fight any other fighter in their weight division as directed by the league, subject to commission approval.
- d) Weight divisions may be adjusted to conform with commission requirements.

1.3 - Commissions

Fights throughout the 2023 PFL Europe Season will be held in various jurisdictions, and each fight will be governed by the regulations and rules of the commission or sanctioning body for the jurisdiction in which the fight takes place, or as otherwise directed by PFL. Should an inconsistency arise at any point throughout the season between the application of the league rules and applicable commission rules, the commission rules will take precedence, with the exception of variances approved by the commission. Tiebreakers and playoff brackets for intra-league purposes are within the discretion of the league.

1.4 - Code of Conduct

All fighters, corners, managers, coaches, friends and family members will be required to abide by the league rules and code of conduct while present at any PFL Europe event or ancillary league-related function. The PFL Europe code of conduct is posted at the following link:

www.pfleurope.com/code

1.5 - MMA Rules

- a) Unless otherwise specified by the governing commission, all PFL Europe bouts will follow the Unified Rules of Mixed Martial Arts published by the Association of Boxing Commissions and Combative Sports at <https://www.abcboxing.com/>, except that:
- i. There will be no elbows allowed anywhere anytime (on the ground, standing, clinch) during the 2023 PFL Europe season. Fighters who violate this rule will be subject to a point reduction, and/or disqualification, at the Commission-appointed referee's discretion.
 - ii. Anything can be reviewed by the commission via instant replay at any time ("Instant Replay Review"), provided there is adequate video evidence and equipment available to facilitate a review. Instant Replay Review is not limited to fight-ending sequences. The most commonly reviewed decisions or non-decisions are for egregious fouls, submissions, knockouts, clock error, and the cause of a cut. The commission supervisor or the referee of the bout may call for an Instant Replay Review. The commission supervisor, referee, and observing referee(s) will review the footage expeditiously. The commission supervisor will make the final decision. The standard of review for any change in a ruling is "self-evident and palpable" error. An Instant Replay Review may only be initiated on a round-by-round basis, meaning before the beginning of the next round in which the conduct in question took place or, if the conduct took place during the final round of the bout, before the result is announced.

1.6 - Gloves

- b) All gloves will be supplied by PFL Europe and will have been previously approved by the commission.
- c) Gloves will be between four and six ounces in weight. Larger sized gloves (3XL-4XL) may slightly exceed the six-ounce limit.

1.7 - Apparel

- a) All apparel sponsorships need to be preapproved by PFL Europe no later than 21 days before bouts (including but not limited to: body art, walkout clothes, apparel and gear, t-shirts, hats, beanies, fight shorts, gloves, robes, shoes, and banners).
- b) Fighters are allowed to wear league-approved MMA board shorts or compression shorts.
- c) Upper body garments (shirts, gi's, tank tops, etc.) are prohibited in the men's divisions, except as authorized by the league and the commission.
- d) Shoes of any kind are prohibited during a fight, except as authorized by the league and the commission.
- e) Fighters and their corners must wear league gear for weigh-ins, walk-outs, and fights.

1.8 - Technology

Fighters may be required to use biometric-sensing and fighter-tracking technology in the SmartCage as approved by both the league and commission.

1.9 - Competition Space

All of the fights will take place inside PFL's SmartCage Decagon. The Decagon is 28 feet long with a 3-foot catwalk.

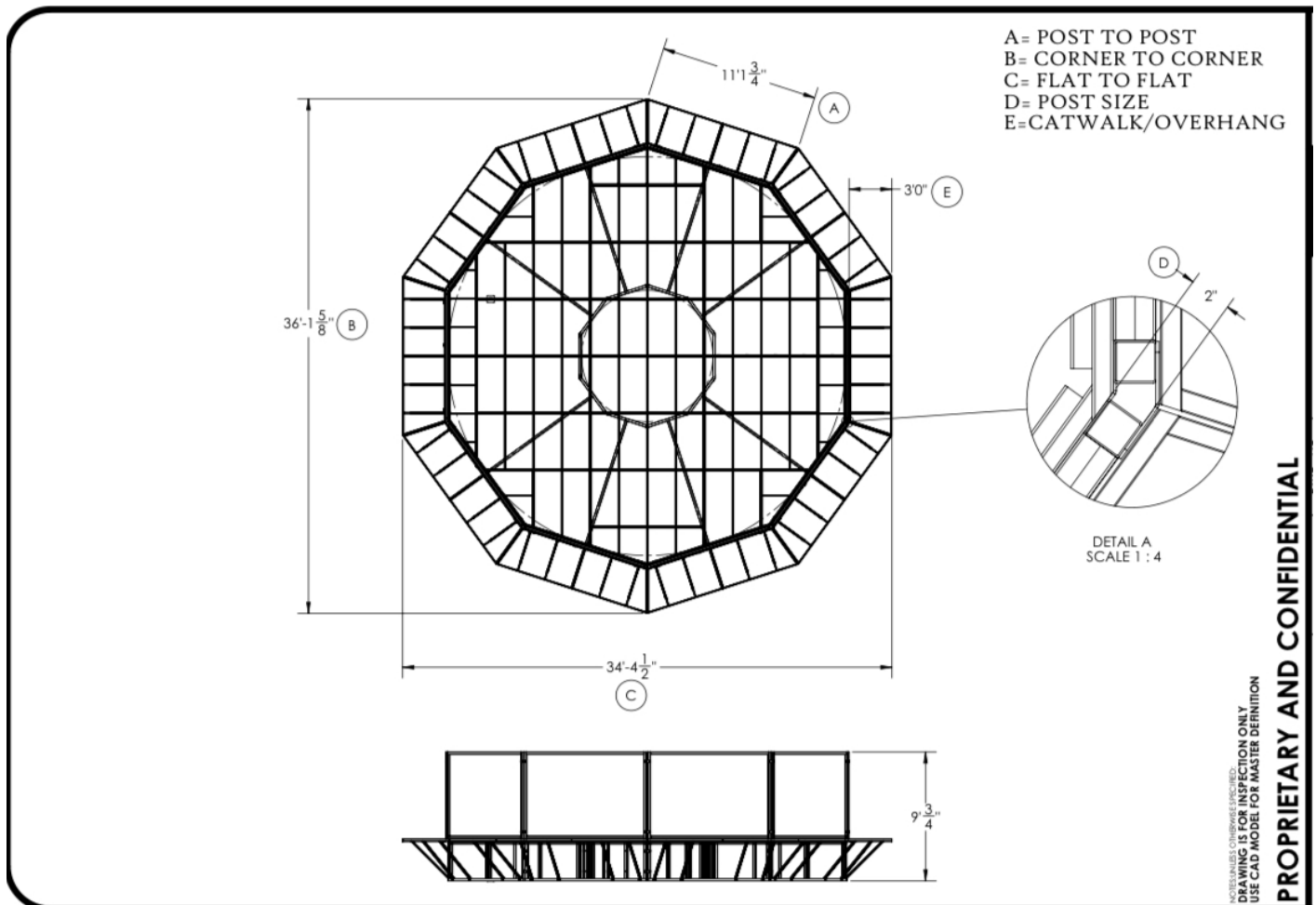

1.10 - Appeal Process

- During the PFL Europe regular season and semifinals, results are based on commission rulings. If a fighter wishes to appeal a commission ruling during the regular season or semifinals, they must do so within 3 business days of the fight in question. The PFL will honor any subsequent changes made by the commission as long as the commission comes to an official decision on the appeal within 30 days of the fight in question. Any decision not made within these parameters will have no bearing on semifinal or final participation. This process does not apply to failed drug tests (for that process see 2.7 and 3.7).
- Any decisions by the commission during the Final will be final at the conclusion of the fight. Any appeal taken of those decisions will have no bearing on compensation or elevation to the PFL global league, except as may be determined by the league at its discretion. This process does not apply to failed drug tests (for that process see 4.5).

2. Regular Season

2.1 - Number of Fights

Each fighter will be scheduled to fight once during the regular season.

2.2 - Bout Specifications

- a) 3 rounds
- b) 5-minute rounds
- c) 1-minute rest period between rounds

2.3 - Results

- a) Fighters who win their bout progress to the semifinals in their weight division.
- b) If a fight ends in a draw, and both fighters made weight, the three judges will each be asked to choose the fighter who they think had the most complete body of work for the entirety of the fight. The fighter chosen most often will advance. This process is subject to commission approval.
- c) If the commission does not approve the above process, the fighter who scored higher on the combined judges' scorecards for the 3rd round will advance. If the two fighters were tied on the combined judges' scorecards in the 3rd round, the same process will be followed for the 2nd round to determine who advances, and so on. If the two fighters are tied on every round, a coin toss will determine the fighter who advances.
- d) If a fighter misses weight, he/she would lose any tiebreaker at the league's discretion.
- e) If a fight results in a No Contest or No Decision during the regular season, the three judges will each be asked to choose the fighter who they think had the most complete body of work for the entirety of the fight. The fighter chosen most often will advance. This process is subject to commission approval.
- f) If the commission does not approve the above process for No Contests or No Decisions, then the following process will apply:
 - 1. If the fight ends before the conclusion of the first round, there will be a coin toss to determine who advances.
 - 2. If the fight ends after the conclusion of the first round, the fighter who scored higher on the combined judges' scorecards for round 1 will advance.
 - 3. If the fight ends after the conclusion of the second round, the fighter who scored higher on the combined judges' scorecards for rounds 1 and 2 will advance. If the two fighters are tied, then the draw tiebreaker in 2.3b will be used to determine the winner.
- g) If a fighter's opponent becomes unavailable for any reason, and there is no alternate available, that fighter will receive a walkover, his/her contracted show and win purse, and will advance to the semifinals, provided that fighter makes weight and is otherwise ready, willing and able to compete.

2.4 - Determining of Opponents

- a) It will be at the sole discretion of the league to determine regular season opponents, subject to commission approval.
- b) The league reserves the right to change matchups at any time.

2.5 - Making Weight

- a) In the regular season, fighters will be allowed a one-pound overage, subject to commission approval.
- b) If a fighter misses weight, and is able to compete, the bout may move forward as scheduled at PFL Europe's sole discretion. The fighter who missed weight will be deducted 1 point on the final judges' scorecards should the fight go to decision, and will be forced to surrender 20% of their total show purse to their opponent. The fighter who made weight will earn their total contracted show purse, plus an extra 20% from their opponent's show purse. Both fighters will be eligible to earn their full win purse and advance based on the outcome of the fight.
- c) If a fighter misses weight and is unable to compete, or PFL Europe decides to withdraw the fighter who missed weight from the bout, that fighter will receive a walkover loss and will not be paid for the fight. In that instance, the PFL will attempt to replace the scheduled opponent with an alternate. If an alternate is available, then the alternate will take the place of the fighter who missed weight. If an alternate is not available, then the fighter who made weight will receive a walkover win, their contracted show and win purse, and will advance to the semifinals, provided that fighter is otherwise ready, willing and able to compete.
- d) If two or more athletes in a weight division miss weight, or become unable to compete for any reason, the league reserves the right to alter matchups so that the minimum number of fights are lost. The fighters who did not make weight, or were unable to compete for any reason, will receive a walkover loss and will not be paid for the fight, at the league's discretion. The fighters who made weight will not receive a walkover, but will earn contracted purse amounts based on their performance in the altered matchup.
- e) If a fighter misses weight or becomes unable to compete for any reason during the regular season, the league may remove them from the competition for the season, including the playoffs.

2.6 - Injuries and Replacements

- a) PFL Europe may have a pool of alternate fighters to draw from in the event that one of the league fighters in a division is unable to compete.
- b) Alternates who fight are eligible to qualify for the playoffs.
- c) In the event that the league is unable to book an alternate to replace a fighter who is unable to compete, the fighter who makes weight and is otherwise ready, willing, and able to compete will be awarded a walkover win, and will advance to the semifinals, as well as his/her contracted show and win purse.

2.7 - Failed Drug Tests

- a) If a fighter fails a drug test after his/her regular season fight, the fighter's appeal period ends 45 days before the semifinals.
- b) Without a successful appeal before the appeal period ends, the fighter may be disqualified from the season at the league's discretion.
- c) Any fighter who lost or drew against a doping fighter receives a walkover win and advances, but does not receive win money.
- d) All failed tests are treated equally (the PFL adheres to each commission's banned substance list).

3. Semifinals

3.1 – Seeding and Matchups

- a) The playoffs will be conducted in a single-elimination bracket format.
- b) Semifinal seeds #1-#4 will be assigned by the league to the 4 fighters who advanced out of the regular season in each division. Semifinal seeds are at the league's discretion.
- c) Semifinal matchups will be determined at the league's discretion. The league reserves the right to change matchups at any time.
- d) Red/blue corner assignments for the semifinals will feature the higher seeded fighter in the red corner. Any alternate who qualifies for the semifinals will automatically be assigned to the blue corner.

3.2 - Bout Specifications

- a) 3 rounds
- b) 5-minute rounds
- c) 1-minute rest period between rounds

3.3 - Tiebreakers

- a) If a fight ends in a draw, and if both fighters made weight, the three judges will each be asked to choose the fighter who they think had the most complete body of work for the entirety of the fight. The fighter chosen most often will advance. This process is subject to commission approval.
- b) If a fighter misses weight, he/she would lose any tiebreaker at the league's discretion.
- c) If the commission does not approve the process in 3.3a, the fighter who scored higher on the combined judges' scorecards for the 3rd round will advance. If the two fighters were tied on the combined judges' scorecards in the 3rd round, the same process will be followed for the 2nd round to determine who advances, and so on. If the two fighters are tied on every round, a coin toss will determine the fighter who advances.
- d) If a fight results in a No Contest or No Decision during the regular season, the three judges will each be asked to choose the fighter who they think had the most complete body of work for the entirety of the fight. The fighter chosen most often will advance. This process is subject to commission approval.
- e) If the commission does not approve the above process for No Contests or No Decisions, then the following process will apply:
 1. If the fight ends before the conclusion of the first round, there will be a coin toss to determine who advances.
 2. If the fight ends after the conclusion of the first round, the fighter who scored higher on the combined judges' scorecards for round 1 will advance.
 3. If the fight ends after the conclusion of the second round, the fighter who scored higher on the combined judges' scorecards for rounds 1 and 2 will advance. If the two fighters are tied, then the draw tiebreaker in 2.3b will be used to determine the winner.
- f) In all of the above circumstances, the official result for records purposes will remain a draw.

3.4 - Making Weight

- a) In the semifinals, fighters will be allowed a one-pound overage, subject to commission approval.
- f) If a fighter misses weight and is able to compete, the bout may move forward as scheduled at PFL Europe's sole discretion. The fighter who missed weight will be deducted 1 point on the final judges' scorecards should the fight go to decision, and will be forced to surrender 20% of their total show purse to their opponent. The fighter who made weight will earn their total contracted show purse, plus an extra 20% from their opponent's show purse. Both fighters will be eligible to earn their full win purse and advance based on the outcome of the fight, at the league's discretion.
- b) If a fighter is removed from semifinal competition due to missing weight, the alternate in that division will step in to that fighter's playoff slot and will compete in the semifinals.

3.5 - Alternates

- a) Each division will have a semifinal alternate, named by the league following the seeding of the playoffs. The league reserves the right to name 0 alternates at its discretion.
- b) Alternates will be chosen at the league's discretion from fighters who are fit and available to compete at a high level in the semifinals.
- c) The alternates will be required to show up at the semifinal event for his/her division and make weight to be eligible to compete in the semifinals should he/she be needed.

3.6 - Injuries and Replacements

- a) If a semifinal-bound fighter becomes unable to compete in the semifinals for any reason after the PFL Europe semifinal brackets are finalized, the alternate in that division will take the actual bracket slot of the unavailable fighter, keeping all other matchups in the division unchanged.
- b) In the event that the league is unable to book an alternate to replace a fighter who is unable to compete, the fighter who makes weight and is otherwise ready, willing, and able to compete will be awarded a walkover win, and will advance to the Final, as well as his/her contracted show and win purse.

3.7 - Failed Drug Tests

- a) If a fighter fails a drug test after his/her semifinal fight, the fighter's appeal period ends 45 days before the Final.
- b) Without a successful appeal before the appeal period ends, the fighter may be disqualified from the season at the league's discretion.
- c) Any fighter who lost or drew against a doping fighter receives a walkover win and advances, but does not receive win money.
- d) All failed tests are treated equally (the PFL adheres to each commission's banned substance list).

4. Final

4.1 - Bout Specifications

- a) 5 rounds
- b) 5-minute rounds
- c) 1-minute rest period between rounds

4.2 - Making Weight

- a) Final bout competitors will not be given any allowance and will have to meet the upper limit of the division they are scheduled to compete in.
- b) If a Final bout competitor fails to make weight, and is able to compete, the bout may move forward as scheduled at PFL Europe's sole discretion. The fighter who missed weight will be forced to surrender 20% of their total show purse to their opponent, will be eligible for a reduced win purse that equals the show purse, and will not be eligible to earn the PFL Europe title. The fighter who made weight will earn their total contracted show purse, plus an extra 20% from their opponent's show purse, and will be eligible to earn their full win purse and the PFL Europe title should they win.
- c) If a fighter is removed from Final competition due to missing weight, the alternate in that division will step in to that fighter's playoff slot and will compete in the Final.

4.3 – Matchups and Alternates

- a) The league reserves the right to change matchups at any time
- b) The league determines Final alternates at their discretion.
- c) The alternate will be required to show up and make weight for the Final in order to be eligible to compete if needed.
- d) If a semifinal winner is unable to compete in the Final, the alternate will step in and compete for the title, provided the alternate makes weight. The winner will be awarded the 2023 PFL Europe title for that weight division.

4.4 - Draws, No Contests and Walkovers

In the event that a Final fight ends in a draw, a no contest, no decision or walkover, no fighter will be awarded the 2023 PFL Europe title for that weight division.

4.5 - Failed Drug Tests

- a) After the Final, if there is a positive drug test, the fighter will have 10 business days to file an appeal. The league will rely on the final determination of the prevailing commission.
- b) Without a successful appeal, the Final bout will be ruled a no contest, no fighter will be awarded the 2023 PFL Europe title for that weight division and no winner bonus will be distributed.